

# Digital Radiation Meter

840024

Instruction Manual

SPER  
SCIENTIFIC

*Environmental Measurement Instruments*

**Digital Radiation Meter 840024**

**Copyright ©2011** by Sper Scientific

ALL RIGHTS RESERVED

Printed in the USA

*The contents of this manual may not be reproduced or transmitted in any form or by any means electronic, mechanical, or other means that do not yet exist or may be developed, including photocopying, recording, or any information storage and retrieval system without the express permission from Sper Scientific.*

**SPER  
SCIENTIFIC** *Environmental Measurement Instruments*

7720 E. Redfield Rd. Suite #7,  
Scottsdale, AZ 85260  
Tel: (480) 948-4448 Fax: (480) 967-8736  
Web: [www.sperscientific.com](http://www.sperscientific.com)

## TABLE OF CONTENTS

INTRODUCTION.....	4
CAUTION .....	5
KEYPAD .....	6
OPERATING PROCEDURES .....	7
METER SETUP .....	8
ESTABLISHING BACKGROUND LEVELS .....	10
AREA MONITORING .....	11
CHECK SURFACE CONTAMINATION ..	12
CHECK AN OBJECT .....	14
MAINTENANCE AND CALIBRATION ...	15
RADIATION AND RADIOACTIVITY .....	17
SPECIFICATIONS .....	21
WARRANTY .....	23
NOTICE .....	24

## INTRODUCTION

This manual provides the necessary information for proper use and care of Sper Scientific Model 840024 Radiation Meter. We recommend reading this manual completely prior to using the instrument. It also contains valuable information about the nature of ionizing radiation that should be understood by the user so that accurate measurements can be made.

This Radiation Meter features selectable measurement scales, adjustable audible alarm and auto power off. It uses a thin wall glass Geiger-Mueller (GM) tube that will detect Beta and Gamma ionizing radiation and X-rays. The GM tube generates an electrical pulse each time radiation passes through the tube. These pulses are then electronically detected and displayed in either SI units (micro-sieverts per hour) or conventional units (milliroentgens per hour).

## CAUTION



### CAUTION

Take extreme care for the following conditions while measuring

Although housed in a high-impact case, the Geiger-Mueller tube that senses radiation is fragile and may break if the unit is dropped, exposed to high temperature (above 122°F/50°C) and/or high humidity (over 90% RH).

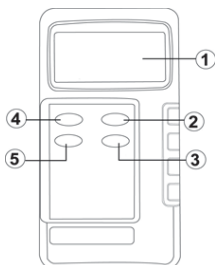

- Do not allow surface of housing to come in direct contact with radioactive contamination
- Do not leave meter in temperatures above 122°F (50°C)
- Do not expose to wet or high humidity conditions
- Do not place meter in a microwave oven
- Do not remove back cover
- Replace battery when  is displayed

## KEYPAD



1. 3.5 Digit LCD display
2. **SET** setup function button
3. **mRem/h (T2)** and setup function down button
4. **⏻** Power **ON / OFF** button
5. **μSv/h (T1)** and setup function up button

## OPERATING PROCEDURES

1. Press the  button. The meter performs a system check and displays all indicators for approximately two seconds together with a Beep signal. When in use, the instrument will emit a “chirping” sound that increases in rate according to the radiation intensity.
2. When powered on, the measurement scale will default to  Micro-Sieverts per hour (T1). Press the  button to change the measurement scale to milliroentgens per hour (T2).
3. Hold the meter as shown on page 12 for detecting Beta radiation. Hold the meter as shown on page 13 for detecting gamma and x-ray radiation.

## METER SETUP

1. To change the factory set alarm level of  $0.5 \mu\text{Sv/h}$  press and release the **SET** button. "ALA" appears in the display followed by the alarm set point. Press the  $\blacktriangle$  or  $\blacktriangledown$  arrows to change the alarm point anywhere in the range of  $0 \sim 199.9 \mu\text{Sv/hr}$ . It is only necessary to set the alarm in the  $\mu\text{Sv/h}$  range. The meter will automatically select the corresponding value for the **mRem/h** range. Once selection is made press and release the **SET** button.
2. To change the 30 minute Auto Power Off default press and release the **SET** button until "APO" appears in the display followed by the current value in minutes. Press the  $\blacktriangle$  or  $\blacktriangledown$  arrows to change the Auto Off setting to anytime from  $0 \sim 60$  minutes (selecting 0 will defeat





## METER SETUP

the Auto Off function). Once selection is made press and release the **SET** button.



3. To cancel or restore audible chirping press and release the **SET** button. The current setting will be displayed (either "ON" or "OFF"). Press the ▲ or ▼ arrows to change the setting. Selecting "OFF" silences audible chirping. Once selection is made press and release the **SET** button to return to the measurement screen.

## ESTABLISHING BACKGROUND LEVEL



There is always naturally occurring radiation around us, which is categorized as background radiation. The radiation levels vary at different locations and at different altitudes. To attain the highest degree of accuracy from this instrument a background reading should be established for each location being monitored. This can be accomplished by taking an unshielded reading or by shielding the meter with a 0.5" thick lead barrier on all sides. The following procedure can be used to obtain a background level:

1. Press the  button
2. Select measurement scale:  or 
3. Take a 5 minute reading
4. Maintain this reading for future reference
5. Repeat this procedure each time meter is moved to a different location

## AREA MONITORING

1. Establish background level as described above
2. Press the  button
3. Select measurement scale:  or 
4. Take a reading by holding the meter in hand or placing it in a convenient location. The meter will display an updated reading once every second. Allow at least one minute for readings to stabilize
5. For environmental monitoring the meter does not have to be held or pointed in a specific direction

## CHECKING FOR SURFACE CONTAMINATION

1. Establish background level (p.11)
2. Press the  button
3. Select measurement scale:  or 
4. Place meter with the GM tube side of the housing facing the surface being monitored (see image A). This allows detection of both beta and gamma radiation. Do not allow the meter housing to come in contact with the surface being monitored as this may contaminate the meter and make it inoperative.

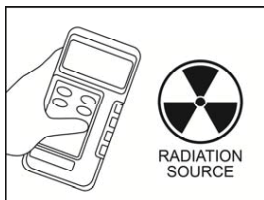

Image A

## CHECKING FOR SURFACE CONTAMINATION

5. The meter is not sensitive to Beta radiation with the GM tube side pointed away from the source being checked (see image B).

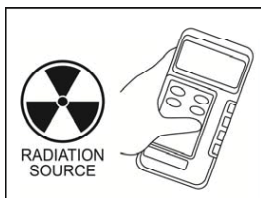





Image B

## CHECKING AN OBJECT

1. Establish background level (p.11)
2. Press the  button
3. Select measurement scale:  or 
4. Hold the meter with the GM tube side positioned as close as possible to the object without allowing contact. If the object is radioactive, the radiation level will be highest at a close distance and will decrease proportionately as the distance from the source increases. (For example, a reading taken at a distance of six inches (152mm) from the object will be approximately one-fourth of the reading taken at a distance of three inches (76mm) following the inverse square law.)

## MAINTENANCE AND CALIBRATION

1. Replace the battery when the  symbol appears in display
2. Remove the battery if meter is not being used for more than one month
3. **This meter should be checked for accuracy once a year.** Our authorized service center can also provide a Certificate of Calibration using NIST traceable standards if required by regulations.
4. For calibration or for out of warranty repair information contact:

**Sper Scientific Ltd.**

Attention: Calibration/Repair  
Department

7720 E. Redfield Rd., Suite #7  
Scottsdale, AZ 85260 USA

**Phone:** 480-948-4448

**Fax:** 480-967-8736

**Email:** [info@sperscientific.com](mailto:info@sperscientific.com)

## **MAINTENANCE AND CALIBRATION**

### **Note:**

This instrument is not user serviceable. Do not attempt making repairs or adjustments. Do not return any meter that may be contaminated with radioactivity.

## **RADIATION AND RADIOACTIVITY**

The following information is intended to provide an understanding of radiation and how the Model 840024 Radiation Meter detects certain types of radiation. Radiation is energy that travels in the form of particles or waves. Radioactivity is the property of some atoms that cause spontaneous emission of energy and emits ionizing radiation as they decay.

### **Understanding Atoms**

Atoms are small particles of which everything is made of. Atoms have a



# **RADIATION AND RADIOACTIVITY**

nucleus that contains protons and neutrons. Neutrons do not have an electrical charge while protons have a positive charge. Electrons are negatively charged particles that orbit the nucleus and balance the positive electrical charge of the protons. The nucleus of the atom is held together by a delicate balance among the nuclear particles allowing the atom to remain stable. Any change in this structure will cause the nucleus to become unstable or radioactive until stability is restored.

## **Ionizing Radiation**

Ionizing radiation is the type most commonly referred to when discussing radioactivity. It is radiation with enough energy to remove tightly bound electrons from the atom creating ions. The GM tube in the radiation meter is capable of detecting ions emitted from certain radioactive particles and waves.

# RADIATION AND RADIOACTIVITY

## Alpha Particles

An alpha particle is identical to a Helium nucleus having two protons and two neutrons. When ionized by radiation the ratio of neutrons to protons is changed in the atom. This causes atoms to restore the balance by emitting alpha particles. Alpha particles are large atoms that travel slowly in air and lose energy rapidly after a few inches or centimeters. This energy is low enough to be stopped by a piece of paper therefore alpha particles can only be detected with specialized equipment. Model 840024 cannot detect alpha particles.

<u>Common Alpha Emitters</u>	<u>Energy MeV</u>
Americium-241	5.48
Uranium-238	4.27
Radium-226	4.87
Radon-222	5.48

# RADIATION AND RADIOACTIVITY

## Beta Particles

Beta particle emission occurs when the ratio of neutrons to protons is too high. An excess neutron transforms into a proton and electron. The proton remains in the nucleus and the electron is ejected. This process causes radioactive decay of the atom. Some beta emitters can also produce gamma rays along with the beta emissions. This energy is in the form of a gamma photon. Beta particles can travel up to several feet (meters) in open air, they are, however, easily stopped by solid objects.

<u>Common Beta Emitters</u>	<u>Energy (MeV)</u>
Carbon-14	0.159
Cesium-137*	0.51
Iodine-131*	0.6
Phosphorus-32	1.71
Sulfur-35	0.16
Strontium-90	0.54
Tritium (Hydrogen 3)	0.018

\*Also decays by gamma emissions. Refer to Gamma Rays and X-Rays section.

# RADIATION AND RADIOACTIVITY

## **Gamma Rays and X-Rays**

Gamma radiation is a high energy ionizing radiation called gamma photons that are emitted from the nucleus of radioactive ions. Because of their high energy gamma rays travel at the speed of light and can travel a long distance before expending their energy. They also have the ability to penetrate objects and human tissue. A dense material such as lead is required for proper shielding of gamma emitters. The major difference between gamma rays and X-rays is how they are produced. Gamma rays originate in the nucleus while X-rays originate in the electron field surrounding the nucleus and are machine produced.

<b><u>Common Gamma Emitters</u></b>	<b><u>Energy (MeV)</u></b>
Cesium-137*	0.662
Iodine-125	0.035
Iodine-131*	0.364
Technecium-99m	0.140

\*Also decays by beta emissions. Refer to Beta Emitters section.

## SPECIFICATIONS

**Display:** 3.5 digit LCD with maximum reading of 1999

**Measurement Range:** 0.1 - 199.9  $\mu\text{Sv/hr}$ ,  
0.01 - 19.99 mRem/hr

**Sensor:** Thin Wall glass GM tube

**Energy Response:** 30KeV to 1.5MeV  
beta, gamma and  
X-ray radiation

**Accuracy:**  $\pm 15\%$

**Alarm Range:** Adjustable from 0 -  
199.9  $\mu\text{Sv/hr}$  (19.99 mRem/hr)

**Overload Indicator:** "OL"

**Low Battery Indicator:** Yes

**Auto Power Off:** Adjustable 0 - 60  
minutes

## SPECIFICATIONS

**Audio Signal:** Selectable “ON” or “OFF”

**Temperature Range:** 5° ~ 122°F  
(5° ~50°C)

**Humidity Range:** 0 ~ 80% RH

**Operating Voltage:** >300VDC

**Battery:** 9V Alkaline - provides up to 50 hours of use

**Weight:** 8 ounces (178g)

**Dimensions:** 5½” x 2⅞” x 1½”  
(143 x 74 x 34 mm)

# WARRANTY

Sper Scientific Ltd. warrants this radiation meter against defects in materials and workmanship for a period of **two (2) years** from date of purchase. Sper Scientific Ltd, will, at its own discretion repair or replace this instrument if it fails to operate properly during the warranty period. This warranty is void by the following: misuse, unauthorized repairs, modifications, radioactive contamination. Please return the warranty registration card within ten (10) days of purchase. For warranty service contact:

Sper Scientific Ltd.  
Attention: Repair Department  
7720 E. Redfield Rd., Suite #7  
Scottsdale, AZ 85260 USA

Phone: 480-948-4448  
Fax: 480-967-8736  
Email: [info@sperscientific.com](mailto:info@sperscientific.com)

Shipping charges for all products returned for service must be prepaid. Please include a description of the problem along with a contact name, phone number and a return address.



## NOTICE

Sper Scientific believes this Radiation Meter to be accurate within reasonable standards of acceptance and includes instructions that, if followed, will yield accurate measurements.

The manufacturer assumes no liability for damages, consequential or otherwise, that may arise from the use of the Radiation Meter by any person, under any circumstances.

This Radiation Meter is sensitive to gamma, beta and x-ray radiation, but not to extremely low energy forms, or alpha, neutron or microwave radiation.

Do not open Radiation Meter or otherwise tamper with or attempt to service it.